

**higher education
& training**

Department:
Higher Education and Training
REPUBLIC OF SOUTH AFRICA

NATIONAL CERTIFICATE (VOCATIONAL)

**PLUMBING
NQF LEVEL 3**

NOVEMBER 2010

(12030373)

**23 November (X-Paper)
09:00 – 12:00**

Candidates will require drawing instruments.

This question paper consists of 7 pages.

<p style="text-align: center;">TIME: 3 HOURS MARKS: 100</p>

INSTRUCTIONS AND INFORMATION

1. Answer ALL the questions.
 2. Read ALL the questions carefully.
 3. Start EACH question on a new page then answer all its sub-sections.
 4. Number the answers according to the numbering system used in this question paper.
 5. A '*labeled sketch*' is a neatly drawn sketch or illustration. It is done in pencil and must be clear and large enough so that all details can be seen. You have to draw in labels which are descriptions or names to explain the sketch.
 6. Cross out any answers, or part thereof, which must not be marked by drawing a line through it.
 7. Write neatly and legibly.
-

QUESTION 1: COLD WATER RETICULATION

- 1.1 What is the function of an inline strainer? (2)
- 1.2 Explain siphonic action with the aid of FIGURE 1 by giving a description of what is happening at the three positions indicated by the arrows. Write your answers next to each question number (1.2.1 – 1.2.3) IN THE ANSWER BOOK.

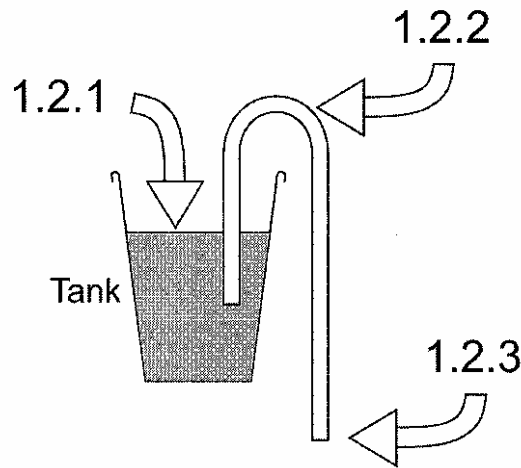

FIGURE 1 (5)

- 1.3 Name THREE factors that you will take into consideration when choosing the correct type of pipe support for an installation above ground. (3)
- 1.4 FIGURE 2 shows the lay-out of a water system.

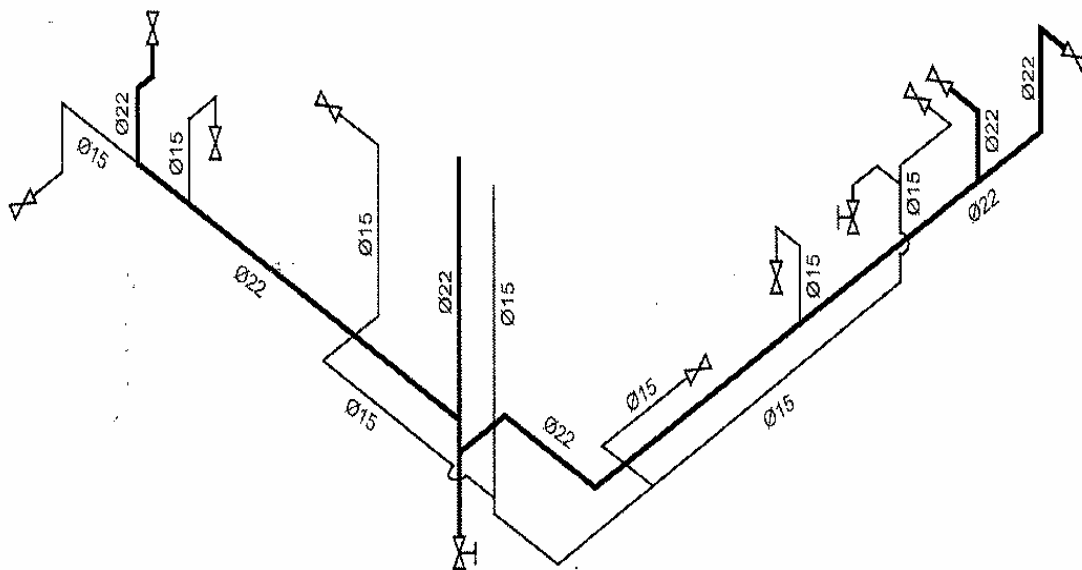

FIGURE 2

All pipes are copper. The 22mm pipes (class 2) are connected with DZR brass compression fittings and the 15mm pipes (class 0) are connected with capillary type fittings.

Draw two columns in your ANSWER BOOK. Label the first column 'DESCRIPTION' and the second column 'QUANTITY'.

Calculate ONLY the quantities of all the different fittings and valves that are required to install this system.

List all the different components, with a full description, and their quantities in these columns.

(10)
[20]

QUESTION 2: HOT WATER RETICULATION

- 2.1 Draw a labeled sketch of a Tee pipe fitting to indicate its *run* and *branch*. (2)
- 2.2 Name THREE advantages of a combination geyser. (3)
- 2.3 The drawing in FIGURE 3 shows a vertical high pressure geyser with components A – E and pipes 1 – 5.

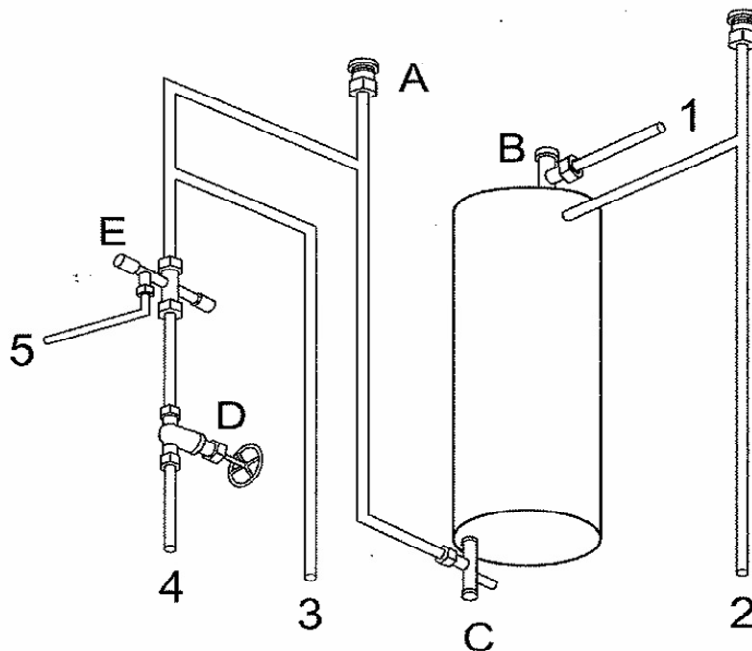

FIGURE 3

Answer the following questions in the ANSWER BOOK.

- 2.3.1 Give the correct name AND symbol for component A. (2)
- 2.3.2 Give the correct name AND symbol for component B. (2)

- 2.3.3 Give ONLY the correct name for component C. (1)
- 2.3.4 Give the correct name AND symbol for component D. (2)
- 2.3.5 Give the correct name AND symbol for component E. (2)
- 2.3.6 Where is pipe 1 leading to? (1)
- 2.3.7 Where is pipe 2 leading to? (1)
- 2.3.8 Where is pipe 3 leading to? (1)
- 2.3.9 Where is pipe 4 leading to? (1)
- 2.3.10 Where is pipe 5 leading to? (1)
- 2.4 What is the pressure rating of a combination pressure control and pressure relief valve which is blue color coded? (1)
- [20]**

QUESTION 3: ABOVE GROUND DRAINAGE SYSTEMS

- 3.1 What is the principle of *Trap Venting*? (3)
- 3.2 What is the function of a trap vent valve? (2)
- 3.3 Draw a labeled sketch to explain a two pipe above ground drainage system. (8)
- 3.4 Name TWO advantages of a one pipe system. (2)
- [15]**

QUESTION 4: SANITARY INSTALLATION

- 4.1 Which type of silicon sealant will you use to seal between a sink and the countertop? (1)
- 4.2 Explain in steps how to fit the taps on a basin. (4)
- 4.3 What would you do to prevent water from leaking between the sink and the grating outlet? (2)
- 4.4 What is the diameter of the waste water pipe used underneath the shower tray? (1)
- 4.5 Which TWO types of water seal traps are used on a bidet? (2)
- 4.6 Name TWO ways of securing a toilet pan to the floor. (2)
- 4.7 Name TWO types of brackets that you can use to hang or fit a wash hand basin. (2)
- [14]**

QUESTION 5: RAIN WATER SYSTEMS

- 5.1 Explain in simple steps how to measure, align and fix gutter brackets to a fascia at the correct gradient. (7)
- 5.2 Draw a simple sketch to show how a galvanized mild steel gutter is fixed to a bracket. (2)
- 5.3 FIGURE 4 shows the sealing and fixing of a fibre cement downpipe. Write the correct names of the components next to the question number (5.3.1 – 5.3.4) IN THE ANSWER BOOK.

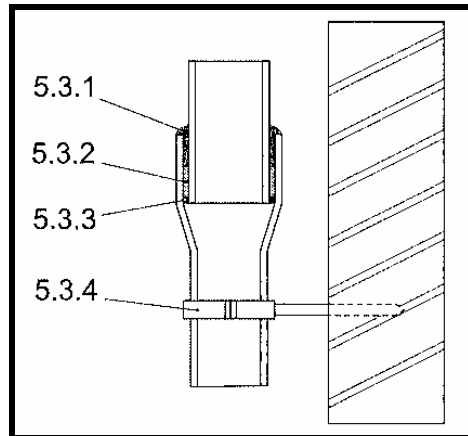

FIGURE 4

(4)
[13]

QUESTION 6: VENT PIPE FLASHING

6.1 Name FOUR types of material that are used to make flashings. (4)

6.2 FIGURE 5 shows stage one in the development of a vent pipe flashing. Answer the questions (6.2.1 – 6.2.6) IN THE ANSWER BOOK.

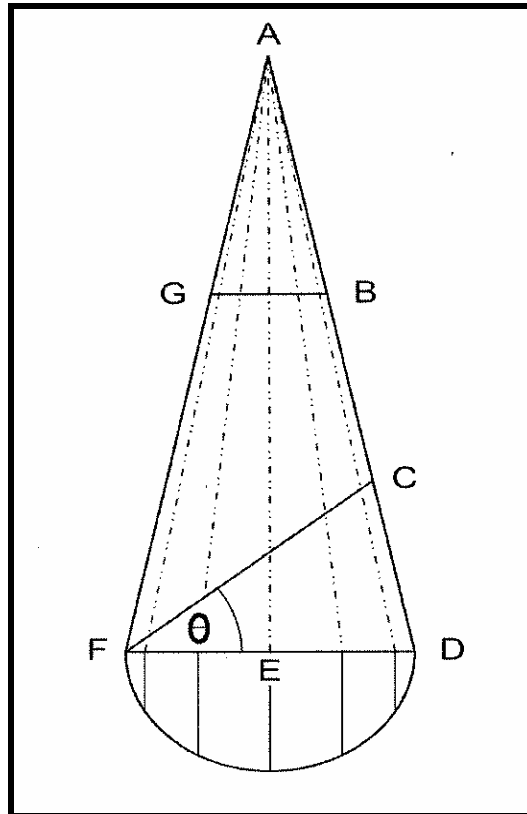

FIGURE 5

(6)

6.2.1 What does line AE represent?

6.2.2 What does line FD represent?

6.2.3 What does line FC represent?

6.2.4 What does line FG represent?

6.2.5 What does line GB represent?

6.2.6 What does angle θ represent?

[10]

QUESTION 7: TRENCHING, EXCAVATION AND TRENCH SUPPORT

Explain in steps how a dumpy level is used to set out a right angled corner.

[8]

TOTAL: 100