



higher education & training

Department:
Higher Education and Training
REPUBLIC OF SOUTH AFRICA

T960(E)(N29)T
NOVEMBER EXAMINATION
NATIONAL CERTIFICATE
MECHANOTECHNICS N4

(8190194)

29 November 2016 (X-Paper)
09:00–12:00

This question paper consists of 6 pages and 1 formula sheet of 3 pages.

**DEPARTMENT OF HIGHER EDUCATION AND TRAINING
REPUBLIC OF SOUTH AFRICA**
NATIONAL CERTIFICATE
MECHANOTECHNICS N4
TIME: 3 HOURS
MARKS: 100

INSTRUCTIONS AND INFORMATION

1. Answer ALL the questions.
 2. Read ALL the questions carefully.
 3. Number the answers according to the numbering system used in this question paper.
 4. Candidates are advised to produce good sketches.
 5. ALL the work done in pencil (excluding sketches, drawings and diagrams) will be regarded as rough work and will NOT be marked.
 6. Write neatly and legibly.
-

QUESTION 1

- 1.1 The most common tests that are performed for corrosion are the salt, humidity and the sulphur-dioxide tests.
- 1.1.1 Briefly explain the process of the salt-spray test. (5)
- 1.1.2 Make a labelled drawing of a salt-spray test. (5)
- 1.2 Since each workshop layout has its individual requirements and conditions under which it has to function, the factors to be considered when designing a particular layout would differ from one to another.
- Name 10 important factors to be considered in the design of a workshop layout. (10)
- 1.3 One of the first observable signs of imminent bearing failure is overheating.
- Briefly describe how you would treat a journal bearing which overheats. (10)
- [30]**

QUESTION 2

- 2.1 The width of the belt in a flat-belt drive is 250 mm and the thickness of the belt is 6 mm, the tension in the tight side of the belt is two and a half times greater than that in the slack side of the belt and the safe working stress is 350 kPa; the pulley has a diameter of 1 500 mm and rotates at 150 r/min.
- Calculate the power transmitted by the belt. (8)
- 2.2 The following particulars apply to an incline belt conveyor:
- | | |
|---------------------------------------|-----------------------------|
| Angle of incline of belt conveyor | = 15° |
| Incline length of the belt | = 120 m |
| Speed at which belt moves | = 2.5 m/s |
| Load conveyed | = 450 tons of rock per hour |
| Force needed to overcome belt tension | = 4 500 N |
- Calculate the power output needed from the motor to drive the system. (6)
- [14]**

QUESTION 3

- 3.1 A shaft, 250 mm in diameter is revolving in a bearing and exerting a force of 75 kN on the bearing. The coefficient of friction between the shaft and the bearing is 0,02 and the shaft rotates at 350 r/min.

Calculate the power lost due to friction. (6)

- 3.2 When a workpiece, 75 mm in diameter is machined on a lathe, the cutting force applied to the cutting tool is 2 500 N. Assume that 15 N.m of torque is lost due to friction in the bearings of the lathe spindle.

Calculate the following:

- 3.2.1 The torque needed at the driving pulley of the lathe. (3)

- 3.2.2 The driving force at the driving pulley of the lathe if it has an effective diameter of 250 mm. (2)

- 3.2.3 The power needed at the driving pulley of the lathe if it rotates at 275 r/ min. (3)

[14]

QUESTION 4

FIGURE 1 below shows a taper of 1-in-5 on the diameter that must be tested for correctness by using 18 mm diameter rollers. The centre distance between the top and bottom rollers is 55 mm. The taper is 80 mm long. The top diameter of the taper is 50 mm.

Calculate from a neat construction of drawings the distance across the top and bottom rollers.

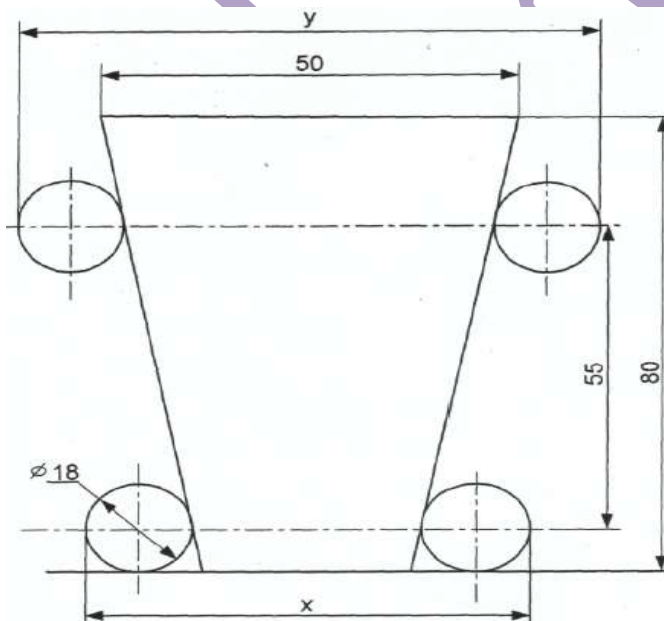

FIGURE 1

[14]

QUESTION 5

An epicyclical gear train is shown in FIGURE 2.

The sun gear B, which is connected to the output shaft, rotates at 120 r/min in a clockwise direction. Gears C and D are mounted on the same axis.

Number of teeth in gear A is 60, while gear D has 20 teeth, gear C 24 and gear B 16 teeth.

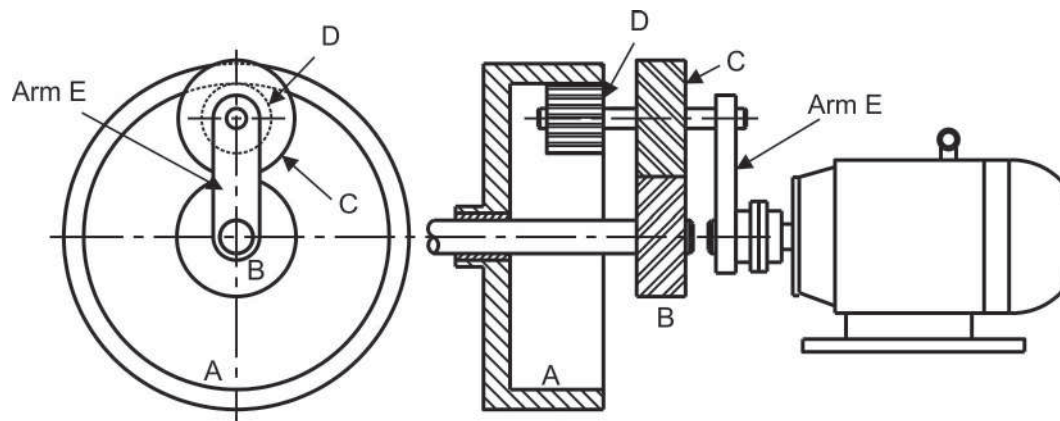
**FIGURE 2**

NO	CONDITIONS	A	B	C	D	ARM E
1	Fix ARM E and rotates A = +1	1				0
2	Multiply by x and add y	x + y				y
3	NE = 0 NB = 120					
4	NA = 0 NB = 120					

Make use of the conditions given in the above table to calculate the following:

- 5.1 The velocity ratio of sun gear B (2)
- 5.2 The velocity ratio of planetary gear C (2)
- 5.3 The velocity ratio of gear D (2)
- 5.4 The speed and direction of the annulus A if arm E is fixed. (4)
- 5.5 The speed and direction of rotation of arm E, assuming the annulus A is fixed. (4)

[14]

QUESTION 6

- 6.1 A horizontal pipe line with a diameter of 90 mm conveys water at the rate of 20 Us with a pressure drop of 40 kPa for every 30 metres pipe line.

Calculate the value of the coefficient of friction (f) for the above mentioned circumstances by using Darcy's formula. (3)

- 6.2 Use Chezi's formula for the circumstances in QUESTION 6.1 and calculate the values of:

6.2.1 The hydraulic mean depth 'm' (2)

6.2.2 The hydraulic gradient 'I' (2)

6.2.3 The Chezi coefficient 'C' (3)

- 6.3 A pipe is 3,5 km long and connects two reservoirs. The difference in water levels between the reservoirs is 40 m. The flow rate of the water in the pipe is 0,75 m³/s and the coefficient of friction is 0,005.

Calculate the following:

6.3.1 Diameter of the pipeline (2)

6.3.2 Hydraulic gradient (2)

[14]

TOTAL: 100

MECHANOTECHNICS N4**FORMULAE**

1. $m = \frac{PCD}{T}$

2. $DO = m \times (T + 2)$

3. $C = \frac{m}{2} \times (TA + TB)$

4. $Ke = \frac{1}{2}mv^2$

5. $VR = \frac{TA}{TB}$

6. $VR = \frac{PCD \text{ of gear}}{PCD \text{ of pinion}}$

7. $VR = \frac{NB}{NA}$

8. $NA \times TA = NB \times TB$

9. $Ft = \frac{2 \times T}{PCD}$

10. $Fr = Ft \times \tan \phi$

11. $F_n = Ft \times \sec \phi$

12. $I_e = IA + (VR)^2 IB + (VR)^2 IC + (VR)^2 ID$

13. $T \nabla = I_e \times \nabla A$

14. $T \alpha = TA + \frac{(NB) TBC}{(NA) \eta_1} + \frac{(ND) TD}{(NA) \eta_1 \eta_2}$

15. $\frac{NB}{NA} = \frac{\omega_B}{\omega_A} = \frac{\alpha_B}{\alpha_A} = \frac{IA}{IB}$

16. $T_{OUTPUT} = T_{INPUT} \times GR \times \eta$

17. $P = \frac{\pi \times PCD}{n}$

18. $T_i + T_o + T_h = 0$

19. $TA = TS + 2TP$

20. $\frac{\text{Input speed}}{\text{Output speed}} = \frac{\text{Teeth on driven gears}}{\text{Teeth on driving gears}}$

21. $v = \pi \times (d + t) \times N$

22. $P = T_e \times v$

23. $\frac{T_1}{T_2} = e^{\mu \theta}$

24. $T_1 = * \times A$

25. $T_c = m \times v^2$

26. $\frac{T_1 - T_C}{T_2 - T_C} = e^{\mu \theta \csc \alpha}$

27. $L = \frac{\pi}{2} \times (D + d) + \frac{(D \pm d)^2}{4 \times C} + 2C$

28. $T_g = m \times g \times \sin \phi$

29. $v = T \times r$

$$30. v = \sqrt{\mu \times g \times r}$$

$$32. v = \sqrt{gr \left[\frac{\mu + \tan \theta}{1 - \mu \tan \theta} \right]}$$

$$34. \frac{T1}{T2} = \left[\frac{1 + \mu \tan \theta}{1 - \mu \tan \theta} \right]^n$$

$$36. \cos \frac{\phi}{2} = \frac{R+r}{C}$$

$$38. T1 = w \times n \times ft$$

$$40. t = \frac{I \times \omega}{T}$$

$$42. T = F \times r$$

$$44. d_o = d_e + 0,65P$$

$$46. h = m \left[1 - \frac{\pi}{4} (\sin \theta \cos \theta) \right]$$

$$47. \frac{p1}{\rho} + \frac{(v1)^2}{2} + gh1 = \frac{p2}{\rho} + \frac{(v2)^2}{2} + gh2$$

$$48. Vw(Va) = \sqrt{\frac{gx^2}{2y}}$$

$$50. hf = \frac{4 \times f \times \ell \times v^2}{2 \times g \times d}$$

$$52. Q = \frac{Cd \times A \times a \times \sqrt{(2gh)}}{\sqrt{(A^2 - a^2)}}$$

$$54. V = \sqrt{(g \times R \times \cos \theta)}$$

$$56. L = 2C + \pi D$$

$$58. \text{One load} = \frac{m2 \times g \times S}{4 \times h}$$

$$31. v = \sqrt{\frac{g \times b \times r}{2 \times h}}$$

$$33. v = \sqrt{gr \left[\frac{h \tan \theta + b/2}{h - b/2 \tan \theta} \right]}$$

$$35. \cos \frac{\theta}{2} = \frac{R-r}{C}$$

$$37. m = w \times t \times L \times \Delta$$

$$39. P = Pg + P\mu$$

$$41. P = \frac{2 \times \pi \times N \times T}{60}$$

$$43. w = d_o + 3d - 1,5155P$$

$$45. w = \frac{\pi \times m}{2} (\cos^2 \theta)$$

$$49. v = C\sqrt{mi}$$

$$51. hf = \frac{f \times \ell \times O^2}{3,026 \times d^5}$$

$$53. Q = Cd \times A \times \frac{\sqrt{(2gh)}}{\sqrt{(m^2 - 1)}}$$

$$55. \text{Vol. bucket} = \frac{m \times s}{\rho \times v}$$

$$57. \text{Self-weight} = \frac{m1 \times g \times S^2}{8 \times h}$$

$$59. T(\text{acc load}) = (T1 - T2)R$$

$$60. T (\text{acc drum}) = I \times \alpha = mk^2 \times \frac{a}{R}$$

$$61. P = T \times T$$

$$63. Ke = \frac{1}{2} I \times \omega^2$$

$$65. P = Ke \times \text{operations/sec}$$

$$67. \mu = \tan \theta$$

$$69. T = \mu \times F \times Re \times n$$

$$71. T = \mu \times n \times (Fc - S)R$$

$$73. Fc = \frac{mv^2}{\gamma}$$

$$74. \text{Tractive effort} = \text{mass on driving wheels} \times \mu \times g$$

$$75. \text{Side thrust} = Fc \cos \theta - mg \sin \theta$$

$$76. \mu = \frac{Fc \cos \theta - mg \sin \theta}{mg \cos \theta + Fc \sin \theta}$$

$$77. P_1 = CmgL + mgh$$

$$62. T = 2\pi \times N$$

$$64. Ke = \frac{\text{work done}}{\text{efficiency}}$$

$$66. (I_1 + I_2) T_3 = I_1 T_1 + I_2 T_2$$

$$68. \eta = \frac{\tan \theta}{\tan (\theta + \phi)}$$

$$70. T = \frac{\mu \times F \times Re}{\sin \theta}$$

$$72. Fc = m \times T^2 \times \gamma$$