



**higher education
& training**

Department:
Higher Education and Training
REPUBLIC OF SOUTH AFRICA

MARKING GUIDELINE

**NATIONAL CERTIFICATE
NOVEMBER EXAMINATION
MECHANOTECHNICS N4
29 NOVEMBER 2016**

This marking guideline consists of 11 pages.

QUESTION 1

1.1 1.1.1

The salt-spray test is done to test the porosity and resistance to ocean-front corrosion of metals. ✓ These metals can be exposed to the salt spray of the sea for a period by constructing a suitable apparatus on the beach, however, ✓ this test is not always practical. An alternative method is to expose the metal to a spray of sodium chloride solution.

A metal workpiece is placed in a test chamber. Sodium chloride is then atomised in a spray nozzle by means of compressed air to form a fine salt mist (fog), before it is let into the test chamber, ✓ where the temperature is thermostatically controlled. The salt mist rises and settles on the test pieces. ✓ These test pieces are suspended at an angle in the test chamber, so that the fog concentrate which settles on them flows and is collected for analysis. ✓

(5)

1.1.2

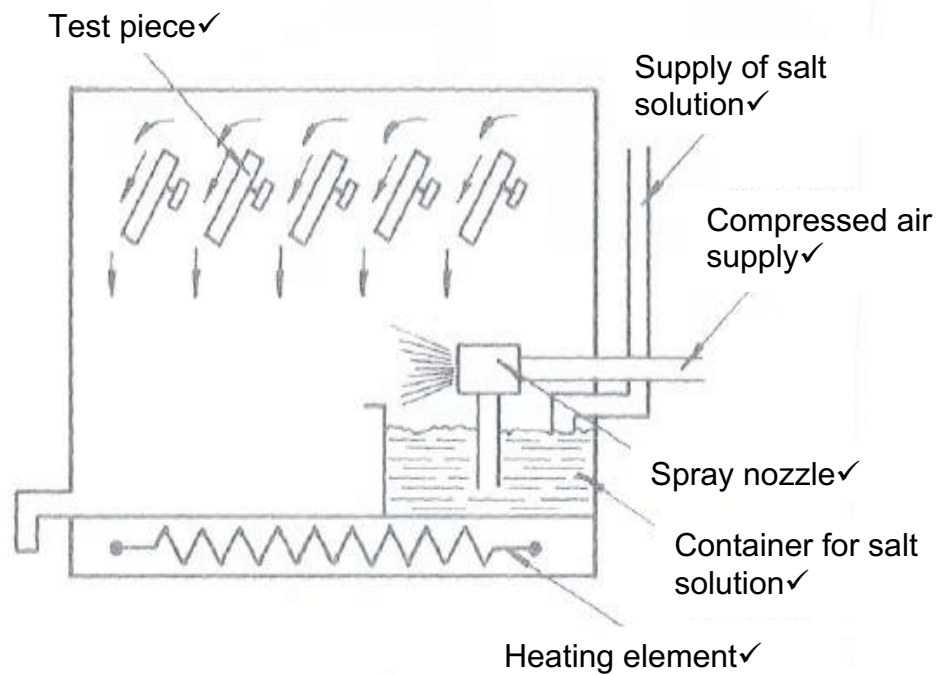

(5)

- 1.2
- Type of production required, e.g. mass production, batch production or individual production.
 - The most effective flow routes for the proposed type of production
 - The required volume of work
 - Inspection requirements to be met.
 - The type of equipment needed, and the quantity thereof.
 - The quantity of material required.
 - Sequence in which production is to take place.
 - Volume of final product to be manufactured.
 - The type and quantity of the available workforce and level of skill of these workers
 - Regulations of local authority
 - Any additional services which are available, for example water, gas, sewerage and electricity.
 - The type and quantity of the available workforce and the level of skill of these workers
 - The storage space available
 - The type of handling equipment to be used.
 - The workshop by-products and waste products which might cause pollution.
- (Any 10 x 1) (10)
- 1.3 Flood the bearing with oil. Do not under any circumstances pour cold water onto the bearing.✓✓ Examine the hot water by feeling it between the fingers to establish whether grit is present. Keep flooding the bearing with oil until no more grit is present.✓✓ Pour oil on the shaft, next to the bearing. Reduce the pressure on the bearing by reducing the load or, if possible reducing the speed at which the bearing is operating.✓✓ If the bearing remains hot, slacken off the bearing-cap nuts.✓✓ After the bearing has cooled down, tighten the bearing and slowly restore the load.✓✓
- (10)
[30]

QUESTION 2

$$\begin{aligned}
 2.1 \quad T_1 &= \text{Stress} \times \text{Area} \\
 &= 350 \times 0,06 \times 0,25 \checkmark \\
 &= 525 \text{ N}
 \end{aligned}$$

$$T_1 = 2,5T_2$$

$$\begin{aligned}
 T_2 &= \frac{T_1}{2,5} \\
 &= \frac{525 \checkmark}{2,5} \\
 &= 210 \text{ N} \checkmark
 \end{aligned}$$

$$\begin{aligned}
 v &= \pi(d + t) \times N \\
 &= \pi(1,5 + 0,006) \times 2,5 \checkmark \\
 &= 11,828 \text{ ms}^{-1} \checkmark
 \end{aligned}$$

$$\begin{aligned}
 P &= (T_1 - T_2) \times v \\
 &= (525 - 210) \times 11,829 \checkmark \\
 &= 3725,82 \text{ W} \checkmark
 \end{aligned}$$

(8)

$$\begin{aligned}
 2.2 \quad P_g &= mgh \\
 &= 125 \times 9,81 \times 120 \sin(15^\circ) \checkmark \\
 &= 38\,085,222 \text{ W} \checkmark
 \end{aligned}$$

$$\begin{aligned}
 P_f &= F \times v \\
 &= 4\,500 \times 2,5 \checkmark \\
 &= 11\,250 \text{ W} \checkmark
 \end{aligned}$$

$$\begin{aligned}
 P_0 &= P_g + P_f \\
 &= 38\,085,222 + 11\,250 \checkmark \\
 &= 49\,335,222 \text{ W} \checkmark
 \end{aligned}$$

(6)
[14]

QUESTION 3

$$\begin{aligned}
 3.1 \quad F_i &= \mu \times F \\
 &= 0,02 \times 75 \times 10^3 \checkmark \\
 &= 1\,500 \text{ N} \checkmark
 \end{aligned}$$

$$\begin{aligned}
 T &= F \times r \\
 &= \frac{1\,500 \times 0,25}{2} \checkmark \\
 &= 187,5 \text{ Nm} \checkmark
 \end{aligned}$$

$$\begin{aligned}
 P &= \frac{2 \times \pi \times N \times T}{60} \\
 &= \frac{2 \times \pi \times 350 \times 187,5}{60} \checkmark \\
 &= 6\,872,234 \text{ W} \checkmark
 \end{aligned} \tag{6}$$

$$\begin{aligned}
 3.2 \quad 3.2.1 \quad T &= F \times r \\
 &= \frac{2\,500 \times 0,075}{2} \checkmark \\
 &= 93,75 \text{ Nm} \checkmark
 \end{aligned}$$

$$\begin{aligned}
 T_k &= 93,75 + 15 \\
 &= 108,75 \text{ N.m} \checkmark
 \end{aligned} \tag{3}$$

$$\begin{aligned}
 3.2.2 \quad F &= \frac{T}{r} \\
 &= \frac{108,75}{0,125} \checkmark \\
 &= 870 \text{ N} \checkmark
 \end{aligned} \tag{2}$$

$$\begin{aligned}
 3.2.3 \quad v &= \frac{2 \times \pi \times D \times N}{60} \\
 &= \frac{2 \times \pi \times 0,25 \times 275}{60} \checkmark \\
 &= 7,2004 \text{ ms} \checkmark
 \end{aligned}$$

$$\begin{aligned}
 P &= F \times v \\
 &= 870 \times 7,2004 \\
 &= 6\,264,3625 \text{ W} \checkmark
 \end{aligned}$$

(3)
[14]

QUESTION 4

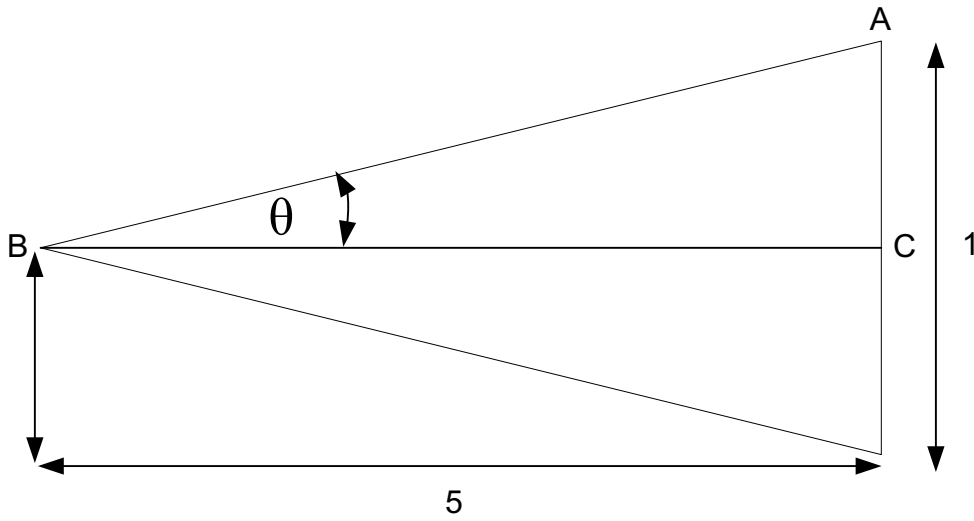

$$\tan\theta = \frac{AC}{BC}$$

$$= \frac{0.5}{5}$$

$$\theta = \tan^{-1}(0.1)$$

$$= 5.711^\circ \checkmark$$

$$\text{Included angle} = 2 \times 5.711^\circ \checkmark$$

$$= 11^\circ 25' \checkmark$$

(3)

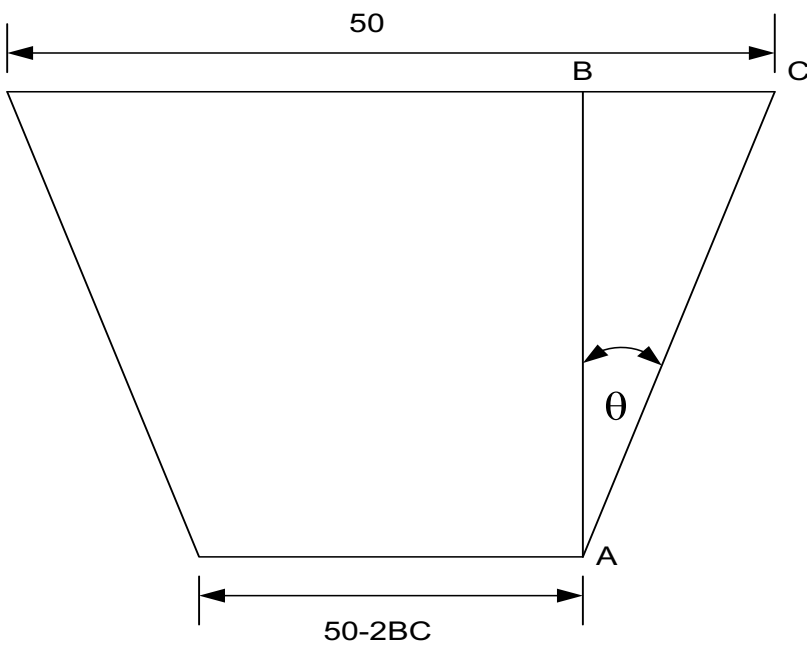

✓

In $\triangle ABC$

$$AB = 80$$

$$\tan\theta = \frac{BC}{AB}$$

$$\begin{aligned} \Rightarrow BC &= AB \tan\theta \\ &= 80 \tan 5.711 \\ &= 8 \text{ mm} \end{aligned}$$

$$\begin{aligned} \text{Small diameter} &= 50 - 2BC \\ &= 50 - 2 \times 8 \\ &= 34 \text{ mm} \end{aligned}$$

(3)

Bottom Roller X

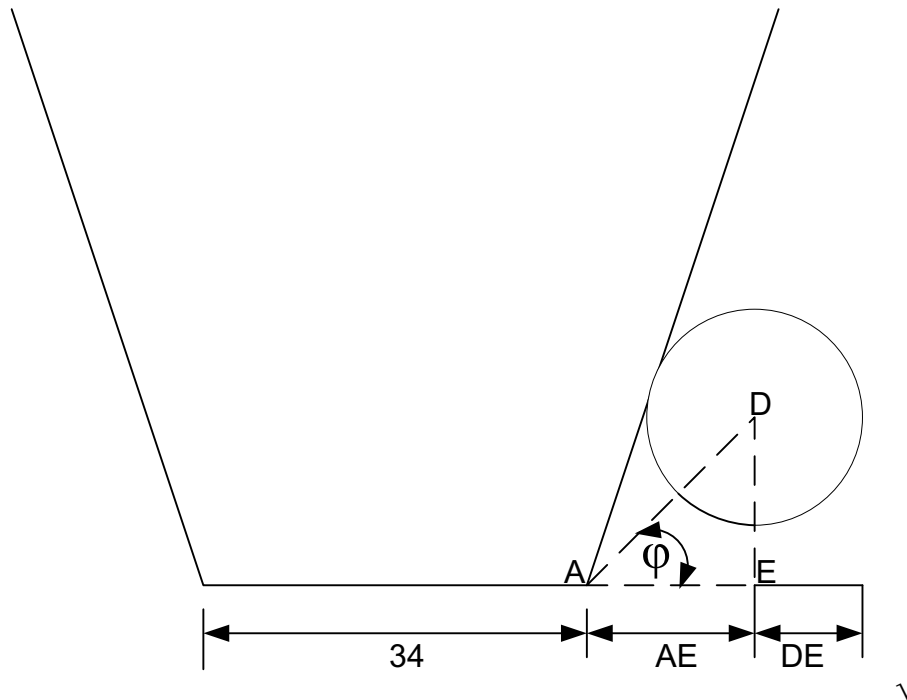

$$X = 34 + 2AE + 2D$$

In $\triangle ADE$

$$\begin{aligned} \phi &= \frac{1}{2}(90 - 5.711) \\ &= 42.145^\circ \end{aligned}$$

(3)

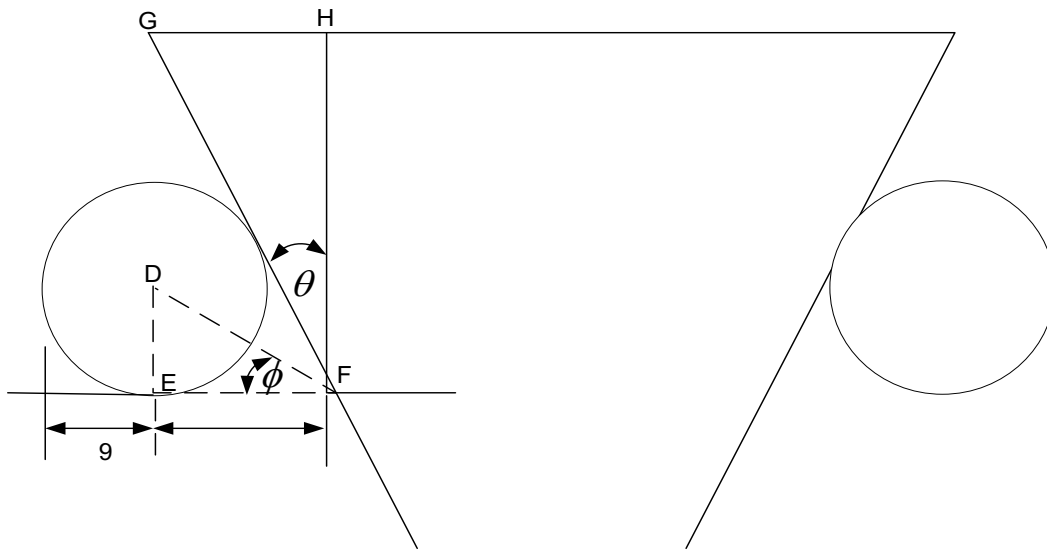

$$EF = AE = 9,944$$

$$\begin{aligned} HF &= 80 - 55 \\ &= 25 \quad \checkmark \end{aligned}$$

$$\tan\theta = \frac{GH}{HF}$$

$$\begin{aligned} \Rightarrow GH &= HF \tan\theta \\ &= 2,5 \tan 5,711 \quad \checkmark \\ &= 2,5 \quad \checkmark \end{aligned}$$

$$\begin{aligned} Y &= (50 - 2GH) + 2 \times 9 + 2 \times 9,944 \\ &= (50 - 2 \times 2,5) + 2 \times 9 + 2 \times 9,944 \quad \checkmark \\ &= 82,89 \text{ mm} \quad \checkmark \end{aligned}$$

(5)
[14]

QUESTION 5

$$5.1 \quad V_B = \frac{60}{20} \times \frac{24}{-16} \quad \checkmark$$

$$= -4.5 \quad \checkmark \quad (2)$$

$$5.2 \quad V_C = \frac{60}{20} \quad \checkmark$$

$$= 3 \quad \checkmark \quad (2)$$

$$5.3 \quad V_D = \frac{60}{20} \quad \checkmark$$

$$= 3 \quad \checkmark \quad (2)$$

$$5.4 \quad N_A$$

$$N_A = x + y$$

$$-4,5x + y = 120 \quad \checkmark$$

$$y = 0$$

$$\Rightarrow -4,5x = 120$$

$$x = -\frac{120}{4,5} \quad \checkmark$$

$$= -26,667 \quad \checkmark$$

$$\Rightarrow N_A = x + y$$

$$= -26,667 + 0$$

$$= -26,667 \quad \checkmark \quad (4)$$

$$5.5 \quad N_E = y \quad \dots\dots\dots(1)$$

$$x + y = 0 \quad \dots\dots\dots(2) \quad \checkmark$$

$$-4,5 + y = 120 \quad \dots\dots\dots(3)$$

$$\text{eqn (2) - eqn (3)}$$

$$5,5x = -120$$

$$x = \frac{-120}{5,5}$$

$$= -21,82 \quad \checkmark$$

$$\Rightarrow y = 21,82 \text{ and } \checkmark$$

$$\text{from (1) } N_E = y$$

$$= 21,82 \text{ r/min } \checkmark \quad (4)$$

[14]

QUESTION 6

6.1

$$h_f = \frac{\text{pressure}}{\text{Rho} \times g}$$

$$= \frac{40 \times 10^3}{1000 \times 9.81}$$

$$= 4.077 \text{ m} \quad \checkmark$$

$$F = \frac{h_f \times 3.026d^5}{L \times Q^2}$$

$$= \frac{4.077 \times 3.026 \times 0.09^5}{30 \times 0.02^2} \quad \checkmark$$

$$= 0.006 \quad \checkmark \quad (3)$$

6.2 6.2.1

$$m = \frac{d}{4}$$

$$= \frac{0.09}{4} \quad \checkmark$$

$$= 0.0225 \quad \checkmark \quad (2)$$

6.2.2

$$i = \frac{h_f}{L}$$

$$= \frac{4.077}{30} \quad \checkmark$$

$$= 0.1365 \quad \checkmark \quad (2)$$

6.2.3

$$v = \frac{Q}{A}$$

$$= \frac{0.02 \times 4}{\pi \times 0.09^2}$$

$$= 3.144 \text{ ms}^{-1} \quad \checkmark$$

$$C = \frac{v}{\sqrt{mi}}$$

$$= \frac{3.144}{\sqrt{0.0225 \times 0.136}} \quad \checkmark$$

$$= 56.215 \quad \checkmark \quad (3)$$

6.3 6.3.1

$$\begin{aligned}d &= \sqrt[5]{\frac{f \times l \times Q^2}{3,026 h_f}} \\ &= \sqrt[5]{\frac{0,005 \times 3,5 \times 10^3 \times 0,75^2}{3,026 \times 40}} \quad \checkmark \\ &= 0,604 \text{ m} \\ &= 604 \text{ mm} \quad \checkmark\end{aligned}$$

(2)

6.3.2

$$\begin{aligned}i &= \frac{h_f}{l} \\ &= \frac{40}{3,5 \times 10^3} \quad \checkmark \\ &= 0,011 \quad \checkmark\end{aligned}$$

(2)

[14]

TOTAL: 100