



**higher education
& training**

Department:
Higher Education and Training
REPUBLIC OF SOUTH AFRICA

MARKING GUIDELINE

NATIONAL CERTIFICATE

APRIL EXAMINATION

MECHANOTECHNICS N4

11 APRIL 2016

This marking guideline consists of 9 pages.

QUESTION1

- 1.1
- Flexibility of layout
 - Coordination of services
 - Accessibility of service and maintenance points
 - Transport routes
 - Optimal use of space
 - Minimising travelling distances of staff and material
 - Minimum handling of material
 - One-way flow of material and products
 - Pleasant working conditions
 - Safety of workers and security of equipment
- (10 × 1) (10)
- 1.2
- 1.2.1
- Viscosity of the paint is too low
 - Atomising air pressure is too high
 - Distance between the spray gun and the work piece is too great
- 1.2.2
- Insufficient air pressure
 - Blocked pipes reduce paint supply
 - Spray nozzle is no longer effective
- 1.2.3
- Spray gun moves too slow
 - Applying too much paint to the surface
 - Paint is too thin
 - Holding the spray gun too close to the surface
- (Any 3)
- 1.2.4
- We use the wrong thinners or solvents.
 - We do not mix the paint properly before use.
 - The air pressure is wrong.
 - We prepare the surface incorrectly.
- (Any 3)
(3 × 4) (12)
- 1.3
- Gravity feed
 - Grease lubrication
 - Splash lubrication
 - Forced lubrication
 - Pressure-feed lubrication
- (Any 3 × 1) (3)

1.4

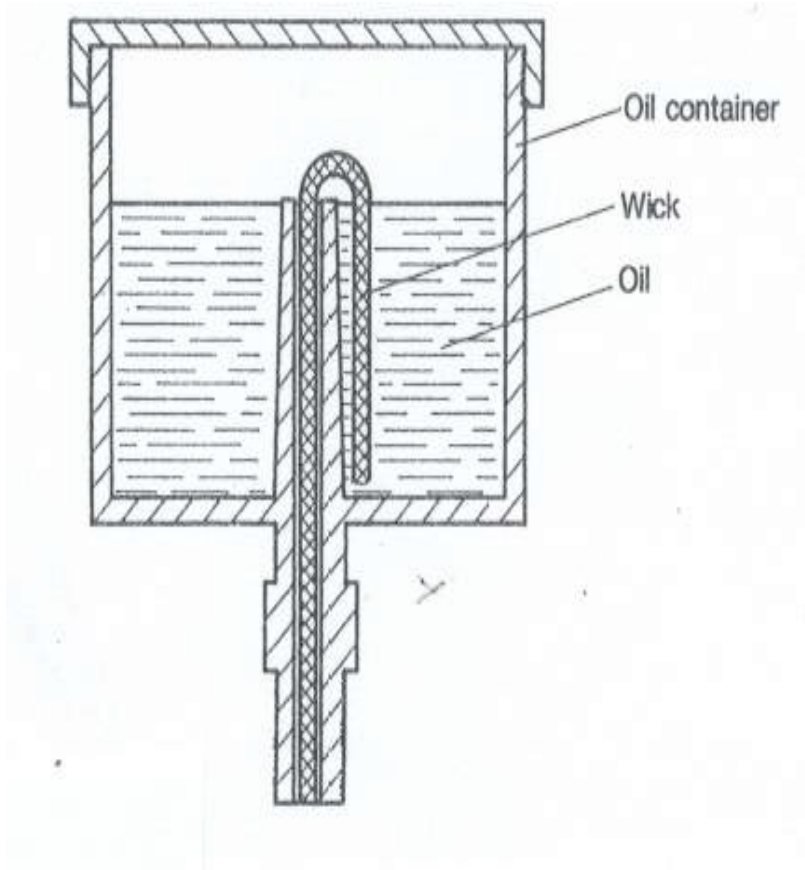

NOTE: TWO marks for the drawing
THREE marks for any three appropriate labels

(5)
[30]

QUESTION 2

2.1
$$V = \pi \frac{(D+t)}{60} N$$

$$= \pi \times \frac{(1,3 + 0,013)}{60} \times 255 \quad \checkmark$$

$$= 17,53 \text{ m/s} \quad \checkmark$$
(2)

2.2
$$T_c = Mv^2$$

$$= 9,75 \times 17,53^2 \quad \checkmark$$

$$= 2996,183 \text{ kg/m} \quad \checkmark$$

$$= 2\,996,2 \text{ kg/m}$$
(2)

2.3
$$T_1 = w \times n \times f_t$$

$$= 1 \times 4 \times 8 \times 1\,000 \quad \checkmark$$

$$= 32\,000 \text{ N} \quad \checkmark$$
(2)

$$2.4 \quad \frac{T_1 - T_C}{T_2 - T_C} = e^{\frac{\theta \times \mu}{57.3}}$$

$$\frac{32\,000 - 2\,996,2}{T_2 - 2\,996,2} = e^{\frac{0,25 \times 172^0}{57.3}} \quad \checkmark$$

$$29\,003,8 = 2,2479(T_2 - 2\,996,2) \quad \checkmark$$

$$T_2 = 15\,898,82 \text{ N} \quad \checkmark \checkmark \quad (4)$$

$$2.5 \quad P = (T_1 - T_2)V$$

$$= (32\,000 - 15\,898,82) \times 17, \quad \checkmark$$

$$= 16\,101,18 \times 17,53 \quad \checkmark$$

$$= 282\,253,685 \text{ W}$$

$$= 282,254 \text{ KW} \quad (2)$$

$$2.6 \quad w = \frac{\text{Total power}}{\text{power per width}}$$

$$= \frac{45}{282,254} \quad \checkmark$$

$$= 0,15943 \text{ mm}$$

$$= 159,43 \text{ m} \quad \checkmark$$

$$= 160 \text{ m} \quad (2)$$

[10]

QUESTION 3

$$3.1 \quad F_f = \mu mg$$

$$= 0,3 \times 150 \times 9,81$$

$$= 441,45 \text{ N} \quad \checkmark$$

$$\text{work done} = \text{Force} \times \text{Distance}$$

$$= 441,45 \times 0,15 \quad \checkmark$$

$$= 66,218 \text{ J} \quad \checkmark \quad (3)$$

$$3.2 \quad \text{Work done} = 175 - 66,218$$

$$= 108,783 \text{ J} \quad \checkmark$$

$$\text{Force} = \frac{\text{Work done}}{\text{Distance}}$$

$$= \frac{108,783}{0,15} \quad \checkmark$$

$$= 725,213 \text{ N} \quad \checkmark \quad (3)$$

3.3

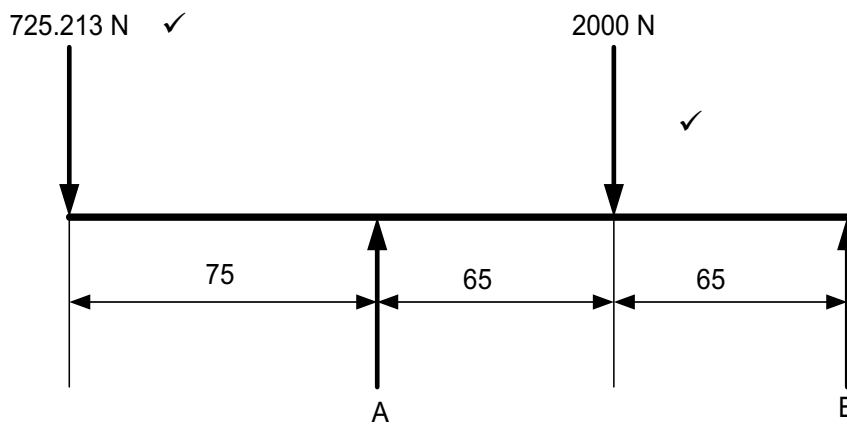

Calculate A, Take moments about point B:

$$CWN = ACWN$$

$$A \times 130 = 2\,000 \times 65 + 725,213 \times 205 \quad \checkmark$$

$$A = \frac{2\,000 \times 65 + 725,213 \times 205}{130} \quad \checkmark$$

$$= 2143,605 \text{ N} \quad \checkmark$$

Calculate B, Take moments about A

$$CWN = ACWN$$

$$2\,000 \times 65 = 725,213 \times 75 + B \times 130 \quad \checkmark$$

$$B = \frac{2\,000 \times 65 - 725,213 \times 75}{130} \quad \checkmark$$

$$= 581,6079 \text{ N} \quad \checkmark$$

ALTERNATIVE METHOD:

Upwards = Downwards

$$A + B = 725,213 + 2\,000$$

$$2\,143,605 + B = 2\,725,213$$

$$B = 2\,725,213 - 2\,143,605$$

$$B = 581,608 \text{ N}$$

(8)
[14]

QUESTION 4

4.1 Micrometer reading:

$$\begin{aligned} d &= 0,577 p \quad \checkmark \\ &= 0,577 \times 3,5 \quad \checkmark \\ &= 2,02 \text{ mm} \quad \checkmark \end{aligned}$$

$$\begin{aligned} w &= D + 3 d + 1,516 p \\ &= 30 + 3 \times 2,02 + 1,516 \times 3,5 \quad \checkmark \\ &= 41,366 \text{ mm} \quad \checkmark \end{aligned} \quad (5)$$

- 4.2 4.2.1
- Calculate the chord height
 - Set the vertical scale of the gear tooth vernier calliper
 - Measure the chord width and compare it
 - Compare the chord width with the calculation and measure it
- (4)

4.2.2

$$\begin{aligned} h &= m \left(1 - \frac{\pi}{4} \sin \theta \cos \theta \right) \quad \checkmark \\ &= 10 \times \left(1 - \frac{\pi}{4} \sin 20^\circ \cos 20^\circ \right) \quad \checkmark \\ &= 7,476 \text{ mm} \quad \checkmark \end{aligned}$$

$$\begin{aligned} w &= \frac{\pi m}{2} \cos^2 \theta \\ &= \frac{\pi \times 10}{2} \cos^2 20^\circ \quad \checkmark \\ &= 13,872 \text{ mm} \quad \checkmark \end{aligned}$$

(5)
[14]

QUESTION 5

5.1 5.1.1
$$\begin{aligned} VR &= \frac{T_A}{T_B} \\ &= \frac{130}{40} \\ &= 3,25 \quad \checkmark \end{aligned} \quad (1)$$

5.1.2
$$\begin{aligned} VR &= \frac{T_A}{T_B} \times \frac{T_B}{T_C} \\ &= -\frac{130}{50} \\ &= -2,6 \quad \checkmark \end{aligned} \quad (1)$$

5.1.3
$$\begin{aligned} y &= 50 \quad \checkmark \\ x + y &= 0 \\ x &= -y \\ &= -50 \quad \checkmark \end{aligned}$$

$$\begin{aligned} N_C &= -2,6x + y \\ &= -2,6 \times (-50) + 50 \quad \checkmark \\ &= 180 \text{ r/min} \quad \checkmark \end{aligned}$$

N_C rotates 180 r/min in the clockwise/positive direction (4)

5.1.4
$$\begin{aligned} y &= 50 \\ -2,6x + 50 &= 0 \quad \checkmark \\ x &= \frac{-50}{-2,6} \\ &= 19,231 \quad \checkmark \end{aligned}$$

$$\begin{aligned} N_A &= x + y \\ &= 19,231 + 50 \quad \checkmark \\ &= 69,231 \text{ r/min} \quad \checkmark \end{aligned}$$

N_C rotates 69,23 r/min in the clockwise/positive direction (4)

$$\begin{aligned}
 5.2 \quad T_B &= \frac{5}{3} T_A \\
 &= \frac{5}{3} \times 30 \quad \checkmark \\
 &= 50 \text{ teet} \quad \checkmark
 \end{aligned}$$

$$\begin{aligned}
 PCDA &= m \times T_A \\
 &= 6 \times 30 \\
 &= 180 \text{ mm} \quad \checkmark
 \end{aligned}$$

$$\begin{aligned}
 PCDB &= m \times T_B \\
 &= 6 \times 50 \\
 &= 300 \text{ mm} \quad \checkmark
 \end{aligned}$$

(4)
[14]**QUESTION 6**

$$\begin{aligned}
 6.1 \quad A &= \frac{\pi D^2}{4} \\
 &= \frac{\pi \times 0,2^2}{4} \\
 &= 0,031 \text{ m}^2 \quad \checkmark
 \end{aligned}$$

$$\begin{aligned}
 m^2 &= \frac{D^4}{d^4} \\
 &= \frac{0,2^4}{0,13^4} \\
 &= 5,59 \quad \checkmark
 \end{aligned}$$

$$\begin{aligned}
 h &= 12,6 L \\
 &= 12,6 \times 0,88 \\
 &= 11,09 \text{ m} \quad \checkmark
 \end{aligned}$$

$$\begin{aligned}
 Q &= C_d \times A \times \sqrt{\frac{2gh}{m^2 - 1}} \quad \checkmark \\
 &= 0,97 \times 0,031 \times \sqrt{\frac{2 \times 9,81 \times 11,09}{5,59 - 1}} \quad \checkmark \\
 &= 0,207 \text{ m}^3 \text{ s}^{-1} \quad \checkmark \\
 &= 207 \text{ L s}^{-1} \quad \checkmark
 \end{aligned}$$

(7)

6.2

$$A_1 = \frac{\pi D^2}{4}$$

$$= \frac{\pi \times 0,2^2}{4}$$

$$= 0,0314 \text{ m}^2 \quad \checkmark$$

$$A_2 = \frac{\pi D^2}{4}$$

$$= \frac{\pi \times 0,4^2}{4}$$

$$= 0,1256 \text{ m}^2 \quad \checkmark$$

$$Q_1 = Q_2$$

$$V_2 = \frac{A_1}{A_2} \times V_1$$

$$= \frac{20}{0,1256} \times 0,0314$$

$$= 5 \text{ ms}^{-1} \quad \checkmark$$

$$\frac{P_1}{\rho h_0 \times g} + \frac{V_1^2}{2g} + h_1 = \frac{P_2}{\rho h_0 \times g} + \frac{V_2^2}{2g} + h_2$$

$$\frac{16 \times 10^3}{1\,000 \times 9,81} + \frac{20^2}{2 \times 9,81} + 0 = \frac{P_2}{1\,000 \times 9,81} + \frac{5^2}{2 \times 9,81} + 1,274$$

$$1,631 + 20,387 = 102 \times 10^{-6} P_2 + 1,274$$

$$P_2 = \frac{1,631 + 20,387 - 1,274}{102 \times 10^{-6}} \quad \checkmark$$

$$= 203\,284,314 \text{ Pa} \quad \checkmark$$

$$= 203,284 \text{ kPa}$$

(7)
[14]**TOTAL: 100**