



**higher education
& training**

Department:
Higher Education and Training
REPUBLIC OF SOUTH AFRICA

MARKING GUIDELINE

**NATIONAL CERTIFICATE
NOVEMBER EXAMINATION
ENGINEERING DRAWING N1**

25 NOVEMBER 2016

This marking guideline consists of 9 pages.

DRAWINGS ARE THE SAME SIZE AS ON THE SYSTEM

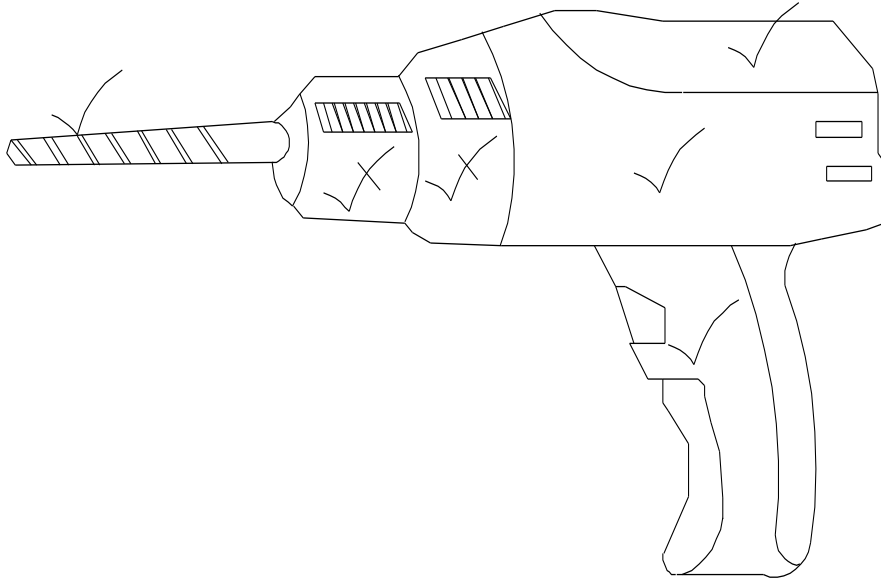
QUESTION 1**DRILLING MACHINE**

CORRECTNESS	5
LINEWORK	2
ACCURACY	1
PROPORTION	2
TOTAL	10

QUESTION 2

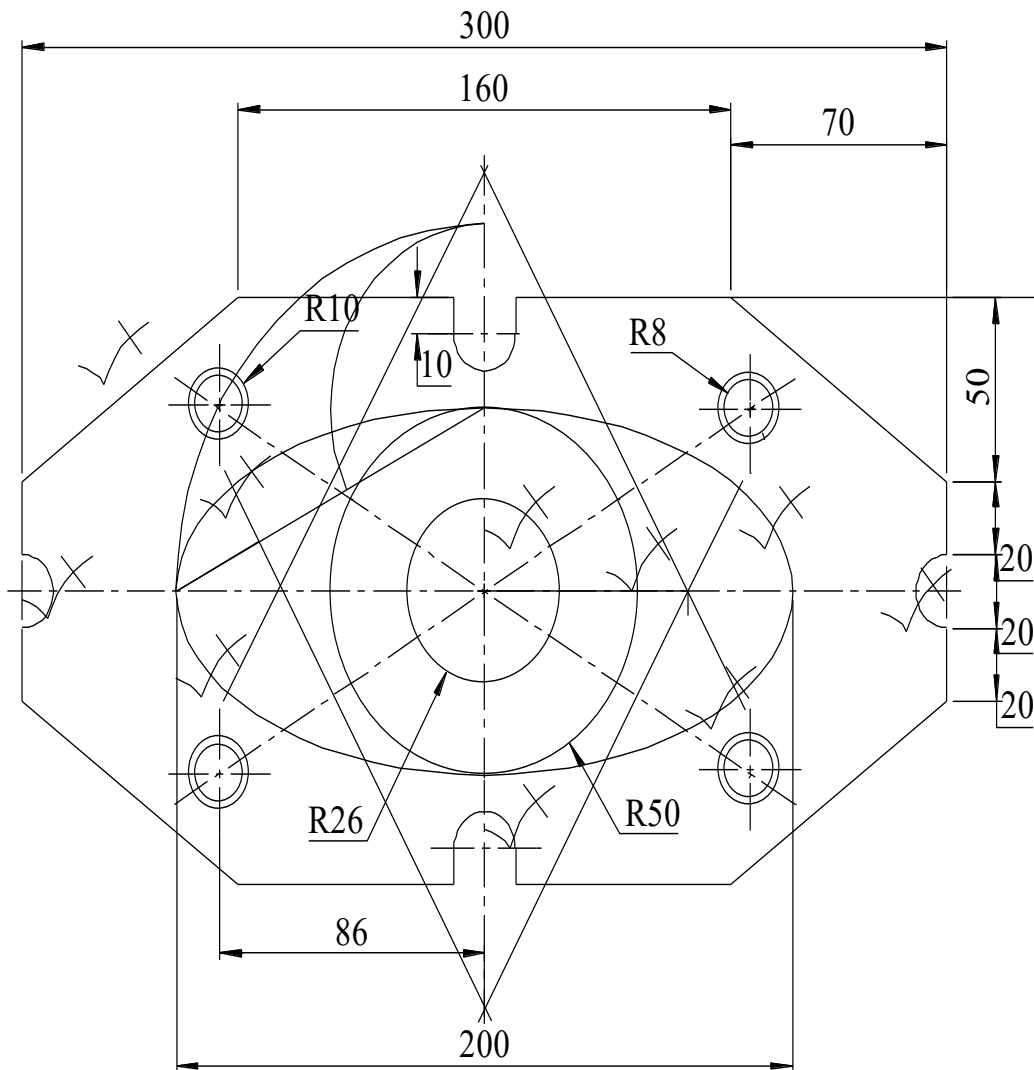

GLAND COVER
Scale 1 : 2

CORRECTNESS	5
LINework	2
CONSTRUCTION LINES	2
ACCURACY	1
DIMENSIONS	3
TITLE AND SCALE	2
TOTAL	15

QUESTION 3

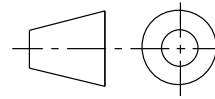
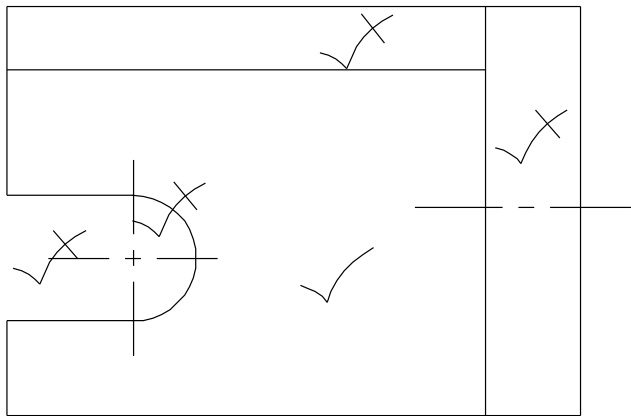
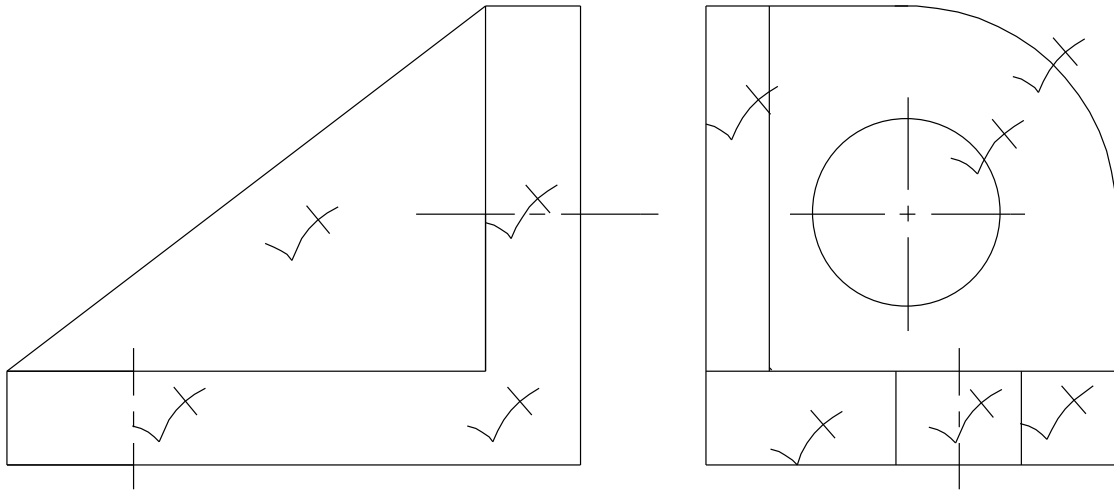

**CASTING
Scale 1 : 1**

	FV	LV	TV
CORRECTNESS	2	3	3
LINework		1	1
ACCURACY		2	
TITLE AND SCALE		2	
PROJECTION SYMBOL			1
TOTAL		16	

QUESTION 4

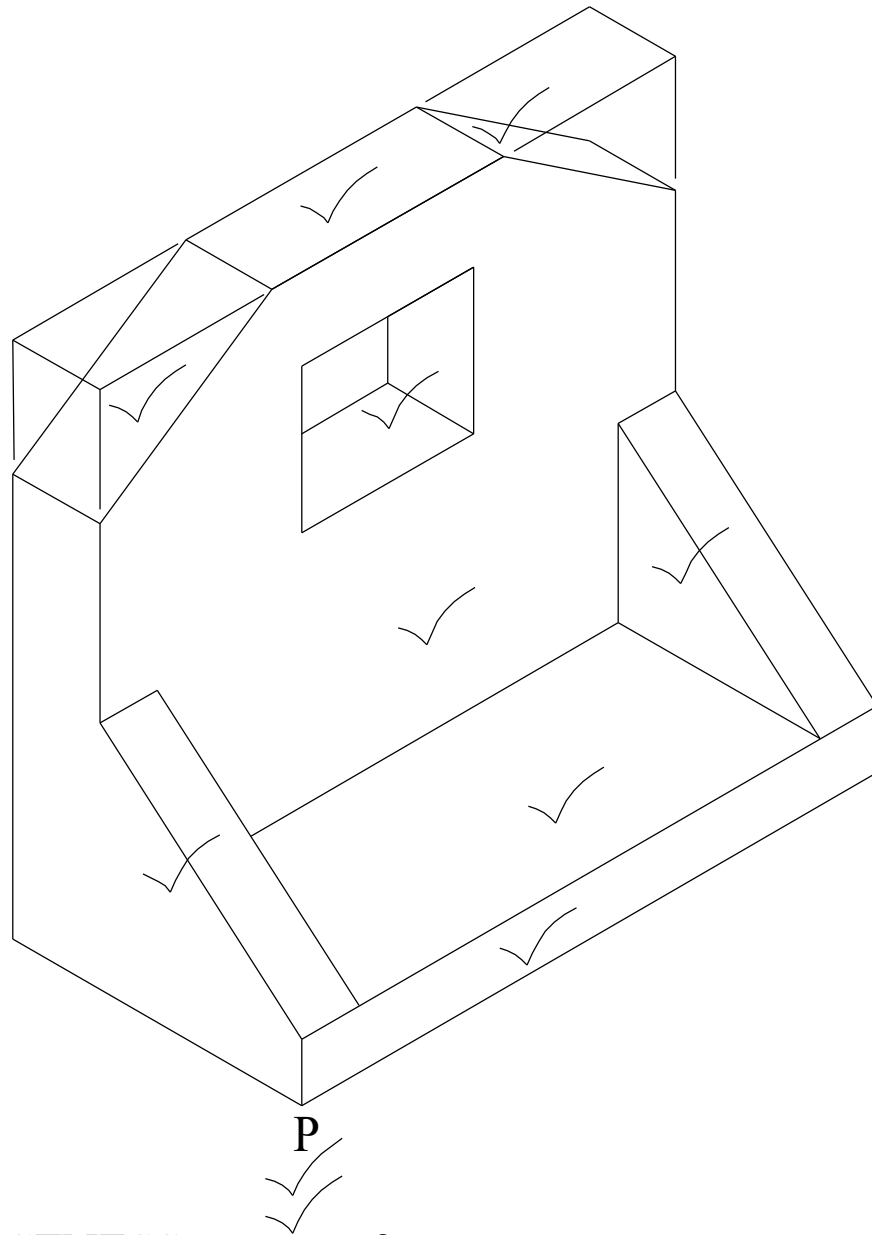

CASTING
Scale 1 : 1

CORRECTNESS	9
LINework	2
ACCURACY	2
LOWEST POINT	2
TOTAL	15